



Determination of Genetic Diversity among Korean Hanwoo Cattle Based on Physical Characteristics

T. J. Choi, S. S. Lee, D. H. Yoon¹, H. S. Kang², C. D. Kim, I. H. Hwang³,
C. Y. Kim⁴, X. Jin⁵, C. G. Yang⁵ and K. S. Seo^{2,*}

Animal Genetics and Breeding Division, National Institute of Animal Science, Rural Development Administration,
San9 Eoryong-ri Seonghwan-eup Cheonan, Chungcheongnam-do 331-801, Korea

ABSTRACT: This study was conducted to establish genetic criteria for phenotypic characteristics of Hanwoo cattle based on allele frequencies and genetic variance analysis using microsatellite markers. Analysis of the genetic diversity among 399 Hanwoo cattle classified according to nose pigmentation and coat color was carried out using 22 microsatellite markers. The results revealed that the *INRA035* locus was associated with the highest F_{is} (0.536). Given that the F_{is} value for the Hanwoo *INRA035* population ranged from 0.533 (white) to 1.000 (white spotted), this finding was consistent with the loci being fixed in Hanwoo cattle. Expected heterozygosities of the Hanwoo groups classified by coat colors and degree of nose pigmentation ranged from 0.689 ± 0.023 (Holstein) to 0.743 ± 0.021 (nose pigmentation level of d). Normal Hanwoo and animals with a mixed white coat showed the closest relationship because the lowest D_A value was observed between these groups. However, a pair-wise differentiation test of F_{st} showed no significant difference among the Hanwoo groups classified by coat color and degree of nose pigmentation ($p < 0.01$). Moreover, results of the neighbor-joining tree based on a D_A genetic distance matrix within 399 Hanwoo individuals and principal component analyses confirmed that different groups of cattle with mixed coat color and nose pigmentation formed other specific groups representing Hanwoo genetic and phenotypic characteristics. The results of this study support a relaxation of policies regulating bull selection or animal registration in an effort to minimize financial loss, and could provide basic information that can be used for establishing criteria to classify Hanwoo phenotypes. (**Key Words:** Hanwoo, Phenotypic Characteristics, Genetic Diversity, Genetic Distance, Phylogenetic Tree)

INTRODUCTION

Animal breeds are developed based on geographic, historical, and evolutionary backgrounds, and are defined by specific phenotypic characteristics. Hanwoo is a cattle breed native to Korea, and is known not only for its

economic importance but also for its ties to country's agricultural heritage. However, recent concerns of the Korean beef cattle industry have placed more emphasis on improving economic quality along with ways to maximize desirable genetic traits of the cattle. These developments served as a challenge, particularly for small-scale cattle enterprises and other operations involved in raising Hanwoo in which the selection criteria such as yellow coat color has become important.

Beginning from 1938, the inspection criteria for Hanwoo generally encouraged the elimination of animals with black or striped hair. In 1975, the Ministry of Agriculture and Forestry in Korea established new inspection criteria for breeding and candidate breeding stocks. These regulations also mandated that yellowish brown coat color for breeds with differing hair and nose color were a basis for disqualification. Furthermore, Hanwoo appearance inspection criteria as mandated by Korea Breeding Stock Improvement Association Notice No. 97-7 sought to unify the appearance of cattle by excluding

* Corresponding Author: K. S. Seo. Tel: +82-61-750-3232, Fax: +82-61-750-3232, E-mail: sks@scnu.kr

¹ Department of Animal Science, Kyungpook National University, 386 Gajang-dong Sangju, Kyungpook, 742-711, Korea.

² Department of Animal Science and Technology, Sunchon National University, Sunchon, 540-742, Korea.

³ Department of Animal Science, Chonbuk National Univ., 567 Baekje-daero Deokjin-gu Jeonju, Jeollabuk-do 561-756, Korea.

⁴ Hanwoo Improvement Center, National Agricultural Cooperative Federation, 6-10 Wonbul-ri Unsan-Myun Seosan, Chungcheongnam-do, 356-831, Korea.

⁵ College of Agriculture, Yanbian University, Park Road 977 133002 Yanji, Jilin, China.

Submitted Mar. 6, 2012; Accepted Apr. 30, 2012; Revised Jun. 4, 2012

animals with white spots and a black nose. Despite these efforts, in the latter half of 1970s the purebred improvement project that included production of a pure Hanwoo lineage breeding complex and an initiative to develop new breeds by crossbreeding introduced breeds with Hanwoo was initiated. The intent was to create new crossbreed lineages that had desirable characteristics of both breeds. However, this project led to the decision to allow the import of beef cattle following complaints by farmers due to lower prices of beef in 1979 (Roh, 2008). The assumption that prompted this decision was due to crossbreeding which increased the prevalence of undesirable hair color (*i.e.*, other than yellowish brown) and black noses among Hanwoo cattle. Farmers were concerned that the breeding program was fueling decreases in beef prices (a reduction of approximately \$100 per head of cattle). Furthermore, the program was also believed to have reduced the quality of breeding stock, exemplified when candidate and certified breeding bulls with otherwise excellent characteristics were disqualified due to their appearance (approximately 57%). The large number of disqualified and cheaper animals resulted in an annual economic loss of about \$2.3 million. However, there is virtually no information about the frequencies of black noses or different coat colors observed among Hanwoo cattle in the Republic of Korea (Lee et al., 2002).

The recent development of phylogenomics combined with phylogenetics to study the degree of similarity and diversity among genetic characteristics between different breeds and to understand the regulatory mechanisms of gene expression has proven to be increasingly important (Philippe and Blanchette, 2007). Systematic research protocols using genetic markers for analyzing native stocks

or animals are utilized in many countries. These studies usually involve biological markers such as blood and milk proteins. However, since the mid 1990s microsatellite markers have been more widely used to assess genetic diversity, origin and lineage, genetic characteristics, and the preservation of conventional stocks (MacHugh et al., 1998; Loftus et al., 1999; Martín-Burriel et al., 1999). High mutation rates and co-dominant nature has permitted the estimation of genetic diversity within or between breeds, including genetic admixtures among breeds, even when closely related.

The goal of the present study was to use these recent analytical innovations to evaluate the genetic characteristics of Hanwoo cattle and determine the genetic criteria for physical Hanwoo traits. This would provide basic data to help establish criteria for breed appearance and registration. Twenty-two microsatellite markers were utilized for phylogenetic analysis of different Hanwoo groups that were established based on coat and nose color.

MATERIALS AND METHODS

Materials

The present study used data from a previous investigation of Hanwoo physical traits and blood collection sampling from 2006 to 2008 involving general breeding farms and institutions throughout the Republic of Korea. Classification of the physical appearance of each animal (Figure 1) was performed according to characteristics such as a black nose, white or black coats (group A), and white or black spots (group B). Individuals with a spot that was clearly distinguished in a yellow coat were placed into a separate group. Cattle with black noses were further



Figure 1. Hanwoo cattle with partial white or black coats mixed with brown (A), spotted white coat separated with brown (B), degree of nose pigmentation (C).

Table 1. Numbers of animals from each region and in all groups used for the analysis

Province	City	Coat color			Normal	Nose pigmentation					Hol
		WT	BL	WS	B	Ba	Bb	Bc	Bd	Be	
Chungnam	Boryung	3	4	8	4	3		1	1		
Kangwon	Samcheok	1		1	5		2	2	1	3	
Kyungki	Ansung		4		1						
	Icheon	1			1	2	2				
	Yangpyung	4	2		1	11	5	3		2	
	Yongin					1	2		1		
	Yuncheon	2	3	1	5	4	7	4	1	1	
Jeonnam	Goheung		1	1	1	4		1	2	2	
	Yungam		1		2		1	4		1	
Jeonbuk	Buan	1						1			
	Jangsu				12	7		1			
Nonghyup		16	11		108	27	11	4			
NIAS											69
Total		28	26	11	140	59	30	21	6	9	69

WT = White coat mixed with brown, BL = Black coat mixed with brown, WS = White spotted coat separated with brown, B = Hanwoo cattle with a cuticolor nose and pure brown coat, B (a to e): B (a to e): a-e represent different degree of nose pigmentation with "a" being the lightest and "e" the darkest, Hol = Holstein animals utilized as dairy cattle in Korea, NIAS = National Institute of Animal Science in Korea.

subdivided into five categories (a to e) based on the degree of nose pigmentation. A black spot on the coat was excluded as a distinct physical trait since no cattle with a black spot were observed. Cattle with one or more of the following traits were excluded from the experiment: a black nose, white hair, and a black or white spot. Holstein cattle were first introduced into Korea in the 1960s and until now have been used as a dairy breed. Holstein cattle were used as a separate reference group for a comparative analysis because the coat or nose color observed in our study could have possibility arisen from crossbreeding between Hanwoo and Holstein. The numbers of animals from each region included in our survey are shown in Table 1.

Experimental analysis

DNA was extracted using the method described by Boom et al. (1990). Primers specific for 22 selected microsatellite markers (*BM1818*, *BM1824*, *BM2113*, *CSSM66*, *ETH3*, *ETH10*, *ETH152*, *ETH225*, *HEL1*, *HEL5*, *HEL9*, *ILST005*, *ILST006*, *INRA005*, *INRA023*, *INRA032*, *INRA035*, *SPS115*, *TGLA57*, *TGLA122*, *TGLA126* and *TGLA227*) that were recommended by the International Society of Animal Genetics were used for PCR analysis. Multiplex PCR was carried out for nine sets of three markers. PCR fragment size was analyzed by least square for ternary simple regression according to the color of the fluorescence-dyed microsatellite and allele size distribution using a 3130XL genetic analyzer (Applied Biosystems). Allele size for the microsatellite loci was determined with GeneMapper (version 3.7) software (Applied Biosystems).

Statistical analyses

The genes detected at each locus were directly counted.

The average number of alleles for the groups and allelic frequencies were compared and expressed as percentages. The observed heterozygosity (H_O), allelic frequency (Weir, 1996), and expected heterozygosity (H_E ; Nei, 1987) in Hardy-Weinberg (H-W) equilibrium determined the genetic diversity within a group. All allelic frequencies for each group along with locus heterozygosity were analyzed using Excel Microsatellite toolkit version 3.1 (Park, 2001).

To overcome the difficulty in comparing the numbers of alleles between groups since these numbers increase in proportion to the number of individuals in the groups, allelic richness (El Mousadik and Petit, 1996) was evaluated. An estimated number of alleles contained in $2n$ genes extracted again from $2N$ genes was compared ($N \geq n$) for each marker (R_s) and group (R_g). F-statistics (Weir and Cockerham, 1984) also reduced error as the sample size increase by setting a weight-to-allele frequency according to sample size. F-statistics were analyzed for each locus and pair-wise tests were carried out for each group as previously described (Cockerham and Weir, 1993). Allelic richness as well as F-statistics analyses and tests for each group and locus were performed using the FSTAT program, version 2.9.3 (Goudet, 2001).

Genetic distance was calculated using allele frequencies to determine the genetic relationships among populations and breeds. For this, D_A genetic distance (Nei, 1983), an accurate analysis of phylogenetic trees regardless of the presence of a bottleneck effect, was used in the present study. A distance matrix was calculated for each population and individual animal with the DISPAN (Ota, 1993) and MICROSAT programs (Minch, 1998), respectively.

Phylogenetic trees were generated using genetic distances that are suitable for numeric data. For this, the

neighbor-joining (NJ) method was used because it has been reported that this technique does not apply the rate of evolution equally (Saitou and Nei, 1987). In addition, it has a relatively high bootstrap value and is recommended for generating phylogenetic trees. The DISPAN program (Ota, 1993) and the NEIGHBOR package (Felsenstein, 2007) from PHYLIP software (version 3.67) were used. Resampling through bootstrapping was repeated 1,000 times to test the reproducibility of the phylogenetic tree structure. Correlations among breeds according to allelic frequencies in each population were analyzed with the XLSTAT program (www.xlstat.com). In addition, the principal components were analyzed based on the allele frequencies.

RESULTS AND DISCUSSION

Analysis of genetic diversity in each group

Heterozygosity and the number of alleles of the Hanwoo groups were formed by the classification based on different hair color and black nose (Table 2). The expected heterozygosity for the different groups range from 0.689 ± 0.023 (Hol) to 0.743 ± 0.021 (Bd) while the average expected heterozygosity for all groups was 0.716 ± 0.025 . The Korean Holstein group was found to have a lower heterozygosity than Hanwoo, and almost all of the cattle in the Hanwoo group showed a similar level of heterozygosity. However, the black nose stage 2 group (Bb) and normal appearance group (B) had a relatively lower degree of heterozygosity, indicating that variation in these groups was slightly different from that of other groups. Other studies examining Korean Holstein cattle have reported similar levels of heterozygosity such as 0.714 (Kim et al., 2001), 0.668 (Yoon, 2002), and 0.682 (Yoon et al., 2005).

In addition, expected heterozygosities of the Hanwoo group evaluated in this study were greater than those of

most other breeds, including Swiss (0.60 to 0.69; Schmid et al., 1999), Czech (0.415 to 0.506; Cítek et al., 2006), Spanish (0.41 to 0.69; Martín-Burriel et al., 2007), Indian Tharparkar (0.67), Hariana (0.53), Deoni (0.59; Sodhi et al., 2006), and Indian water buffalo (0.63 to 0.70; Vijn et al., 2008), the Central West African *Bos indicus* and *Bos taurus* breeds (0.512 to 0.656; Ibeagha-Awemu et al., 2004) and 0.683, 0.753 and 0.629 for Northeast China, Middle China, Southern China, respectively, among 27 Chinese cow breeds (Zhang et al., 2007). Genetic diversity may reflect variation of physical characteristics including hair color, the presence of a white spot, and dark nose pigmentation. For this reason, greater effort should be dedicated to unifying breed characteristics.

The average number of alleles identified in each group was 6.12. The lowest number (4.23) was obtained in the black nose stage 4 (Bd) group while the highest value for the normal appearance group was 8.64. However, the number of alleles (R_t) corrected by sample size was about 2.68 in which almost no difference. The number of alleles in the Holstein group was 2.57, which was smaller than that of the other groups. Nevertheless, among Holstein cattle the number of alleles for the white spot (WS) and black nose stage 4 (Bd) groups were 2.75 and 2.74, respectively, which were greater than the numbers identified in the corresponding groups of other breeds. For stock improvement and selection process, breeds are allocated into several different lineages. However, if the selection of a certain breeding cow or specific lineage is made during the process of stock improvement, the kinship degree increases while heterozygosity decreases (Mateus et al., 2000). In addition, this phenomenon increases the heterogamy loss rate (F_{is}) of the group. It is thought that Hanwoo cattle have been managed competently in terms of lineage control for improving the breed in smaller areas compared to other breeds. Moreover, polymorphic information for Hanwoo

Table 2. Expected and observed heterozygosities and mean number of alleles for 22 microsatellite loci in each group by physical characteristics

Population ¹	Sample size	$H_E \pm SD$	$H_O \pm SD$	Mean no. of alleles	R_t
WT	28	0.717±0.024	0.711±0.020	6.14	2.69
BL	26	0.707±0.026	0.698±0.021	6.45	2.67
WS	11	0.736±0.024	0.715±0.030	5.18	2.75
B	140	0.710±0.026	0.670±0.009	8.64	2.68
Ba	59	0.712±0.025	0.700±0.013	7.36	2.68
Bb	30	0.710±0.024	0.720±0.018	6.27	2.66
Bc	21	0.717±0.023	0.708±0.022	6.14	2.69
Bd	6	0.743±0.021	0.718±0.040	4.23	2.74
Be	9	0.715±0.032	0.666±0.035	4.73	2.69
Hol	69	0.689±0.023	0.683±0.012	6.14	2.57
Total	399	0.716±0.025	0.699±0.022	6.12	2.68

¹ WT = White coat mixed with brown, BL = Black coat mixed with brown, WS = White spotted coat separated with brown, B = Hanwoo cattle with a cuticular nose and pure brown coat, B (a to e): B (a to e): a-e represent different degree of nose pigmentation with "a" being the lightest and "e" the darkest, Hol = Holstein animals utilized as dairy cattle in Korea.

groups was compared to the allele detected to examine differences between the groups; we found that the use of more group-specific markers appeared to be necessary.

To examine the distribution of the 22 microsatellite loci among individual animals within a group, the correlation degree (F_{is}) between individuals in a group was analyzed (Table 3). The overall estimated F_{is} ranged from -0.02 (Bb) to 0.08 (Be), and -0.67 (Bd) to 1.00 (WS), showing considerable differences for each locus in the groups. In particular, there were increased and decreased heterozygosity ratios in the groups at a certain locus. In *INRA035* and *TGLA227*, it was confirmed that homozygosity increased according to nose pigmentation, and the correlation degree (F_{is}) was very high in the Hanwoo groups. Thus, this locus was found to be inappropriate for genetic analysis between Hanwoo groups. However, the *INRA035* locus showed a high similarity of 0.53 (WT) to 1.00 (WS) between individuals in Hanwoo groups (Table 2). This means that the *INRA035* locus appeared to be considerably fixed in Hanwoo cattle.

In contrast, the *ETH3*, *ETH152*, *INRA032*, *ILST005* and *ILST006* loci showed negative correlations between individuals in groups. This finding indicates that as nose pigmentation increases, genetic differences between

individuals increased. However, either significant increasing or decreasing between each nose pigmentation grade and groups with different hair color were not confirmed ($p < 0.05$). It was therefore confirmed that there was uncertainty in group classification according to physical characteristics. The finding that F_{is} values of the *INRA035* locus appear to be greater than those of other loci was previously reported (Jordana et al., 2003). The F_{is} values for 12 out of 18 European cattle breeds were found to be 13.7% (Alentejana) to 69.7% (Tudanca). Additionally, the F_{is} value for 27 Chinese breeds reported by Zhang et al. (2007) was 0.238. This was lower than those for Indian Sahiwal (0.121), Haryana (0.028), Deoni (0.006), Tharparkar (0.093), and Kherigarh (0.064) breeds as reported by Mukesh et al. (2004), Sodhi et al. (2006) and Pandey et al. (2006). In addition, various breeds of Chinese yellow cows were reported to have F_{is} values for *ILST005* and *INRA035* similar to those of Hanwoo cattle, but higher for *HEL5* and *ETH3* loci (Zhang et al., 2007). These results mainly indicated that Chinese cattle breeds have been affected simultaneously by European and Indian regions. Similarly, the *INRA035* locus could be very useful for analyzing the genetic relationship of other breeds derived Indian or African breeds although this locus is assumed to

Table 3. Inbreeding estimates (F_{is}) within Hanwoo and Holstein populations based on 22 microsatellite loci

Locus	WT	BL	WS	B	Ba	Bb	Bc	Bd	Be	Hol
<i>BM1818</i>	0.00	0.01	-0.18	-0.01	0.08	-0.15	0.30	-0.09	-0.09	0.11
<i>BM1824</i>	-0.11	-0.09	0.29	0.03	-0.20	0.04	0.17	-0.33	0.18	-0.01
<i>BM2113</i>	0.06	0.15	0.11	0.10*	0.09	0.05	-0.08	0.23	0.00	0.09
<i>CSSM66</i>	0.02	-0.20	-0.12	-0.01	0.02	-0.13	-0.03	0.18	0.01	0.12*
<i>ETH3</i>	-0.06	-0.04	-0.03	-0.07	-0.09	0.03	-0.21	-0.28	-0.08	-0.07
<i>ETH10</i>	-0.05	0.00	-0.18	-0.02	-0.03	-0.20	0.03	0.38	-0.14	-0.11
<i>ETH152</i>	0.19	-0.15	-0.02	0.05	-0.01	-0.04	-0.25	-0.40	-0.05	-0.02
<i>ETH225</i>	0.00	-0.27	0.17	0.04	-0.08	-0.05	-0.11	0.11	0.63	-0.06
<i>HEL1</i>	0.00	-0.01	-0.15	0.09	0.11	-0.06	0.03	0.07	0.32	0.08
<i>HEL5</i>	0.02	-0.07	-0.15	0.05	-0.03	0.06	0.15	0.11	0.00	-0.01
<i>HEL9</i>	0.03	-0.05	0.04	0.02	0.06	-0.09	-0.05	0.20	-0.05	0.03
<i>ILST005</i>	-0.09	-0.29	0.22	0.10	-0.05	-0.15	-0.17	0.27	-0.08	0.22
<i>ILST006</i>	-0.14	0.13	0.08	0.02	0.11	-0.04	-0.13	-0.21	-0.40	-0.01
<i>INRA005</i>	-0.24	0.07	-0.27	0.10	0.12	0.11	-0.17	0.09	-0.04	0.01
<i>INRA023</i>	0.19	0.08	0.10	0.02	-0.06	0.00	0.01	0.04	-0.05	0.02
<i>INRA032</i>	0.07	0.07	-0.08	0.03	-0.27	-0.24	-0.30	-0.67	-0.15	0.04
<i>INRA035</i>	0.53***	0.70***	1.00***	0.60***	0.68***	0.76***	0.83***	0.75**	0.82***	0.01
<i>SPS115</i>	-0.13	-0.03	0.02	0.02	-0.03	-0.13	-0.01	0.17	-0.19	-0.08
<i>TGLA57</i>	0.00	-0.02	0.46*	0.08*	0.09	0.04	0.11	-0.03	0.45***	0.07
<i>TGLA122</i>	0.05	0.27***	-0.13	0.05	0.07	-0.05	-0.11	0.02	0.01	-0.07
<i>TGLA126</i>	-0.15	0.04	-0.36	0.04	-0.07	-0.09	0.03	-0.36	0.02	-0.11
<i>TGLA227</i>	0.16*	0.01	0.08	0.13***	0.00	0.12	0.22*	0.23	0.26	0.03
All	0.01	0.01	0.03	0.06***	0.02	-0.02	0.01	0.03	0.08*	0.01

WT = White coat mixed with brown, BL = Black coat mixed with brown, WS = White spotted coat separated with brown, B = Hanwoo cattle with a cuticular nose and pure brown coat, B (a to e): B (a to e): a-e represent different degree of nose pigmentation with "a" being the lightest and "e" the darkest, Hol = Holstein animals utilized as dairy cattle in Korea.

* $p < 0.05$, ** $p < 0.01$ and *** $p < 0.001$.

be less efficient as a marker for identifying individuals of the same breed.

Analysis of genetic distance and group relationships

The relationships between Hanwoo groups classified by different hair color and nose pigmentation as well as the genetic relationship with Holstein group were examined. Results of DISPAN analysis used to perform a D_A genetic distance calculation as previously described (Nei et al., 1983) are presented in Table 4. The genetic distance of the Holstein group was far from the D_A values of all Hanwoo groups classified by appearance (0.2267 to 0.3009). Between the Hanwoo groups, the greatest distant from the normal appearance group among the black nose groups was obtained by black nose stage 4 group (Bd; 0.1091). Black nose stage 1 (Ba) was excluded with a D_A of 0.0186. Examination of genetic relationships between groups using F_{st} values produced the same findings as those obtained by D_A genetic distance analysis. Results of a pair-wise test showed that there was no significant difference between Hanwoo groups that were classified by physical characteristics. In addition, Moazami-Goudarzi et al. (1997) reported that F_{st} values are effective for explaining about genetic relationship between the nearest group such as sex or lineages in the same population because it showed more sensitive differences in the same group. However, the absence of significant differences in F_{st} supports the conclusion that variation in the groups of Hanwoo cattle classified by physical characteristics was remarkably different. In addition, as it was confirmed that there were significant differences ($p < 0.01$) among the groups except for black nose stage 5 (Be), significant difference in the relationship between Holstein and Hanwoo was also recognized. This finding mirrored a similar tendency in genetic distances between cow breeds within a country as reported in Portuguese (D_A 0.0326 to 0.1898; Mateus et al.,

2000) and Czech (D_A 0.0172 to 0.0837; Cítek et al., 2006) breeds.

In particular, animals with white hair and a white spot were distinct from cattle in the white hair group as well as the Hanwoo group in the genetic distance analysis. White hairs appear in cows to various degrees. These include roan coat coloring (Seitz et al., 1999; Aasland et al., 2000) characterized by a mix of white or black hair similar to the white or black hair of Hanwoo, white spotting with spots shaped like the white spot in Hanwoo (Olsen, 1981, 1999; Reinsch et al., 1999), the color-sided type (Olson, 1999) in which a side of the body is covered with large spot, the belted type (Rao et al., 2003) featuring a belted waist, and an albino type in which the entire body is covered with white hair (Leipold et al., 1968; Schmutz et al., 2004; Seo et al., 2007). In particular, appearance of the roan coat coloring, which is similar to white hair of Hanwoo, is determined by expression of the Mast Cell Growth Factor (MGF) gene (also called KIT ligand) located in chromosome number 5 and arises from a single base pair mutation (Seitz et al., 1999; Aasland et al., 2000). Since MGF plays an important role in the growth and differentiation of melanocytes, hematopoietic cells, and gametes was found to be related to pigment formation disorders, anemia, and sterility, or are recessive lethal (Pawson and Bernstein, 1990). White coat is one of the hair color characteristics mainly found in Hereford, Shorthorn, Belgian Blue, and Texas Longhorn breeds, and is expressed as the $R/r+$ type heterogamy allele (Seo et al., 2007).

The coats of Holstein, Guernsey, African Sanga, Zebu, and Simmental cattle can have white spots that randomly vary in size, shape, and number. Expression of white spots is determined by synteny of KIT in the sixth chromosome of Holstein and Hereford cattle (Reinsch et al., 1999), and appearance of the four distinct spot shapes depend upon alleles in S and W locus (S^+ , S^H , S^p , and s). The s allele was

Table 4. D_A genetic distances (lower) and population differences (F_{st} , upper) among Hanwoo cattle grouped according to phenotypic characteristics

	WT	BL	WS	B	Ba	Bb	Bc	Bd	Be	Hol
WT	-	0.0037 ^{NS}	0.0093 ^{NS}	-0.0073 ^{NS}	-0.0066 ^{NS}	-0.0032 ^{NS}	0.0124 ^{NS}	-0.0016 ^{NS}	0.0067 ^{NS}	0.1157**
BL	0.0491	-	0.0173 ^{NS}	-0.0011 ^{NS}	0.0006 ^{NS}	0.0033 ^{NS}	0.0084 ^{NS}	0.0045 ^{NS}	-0.0019 ^{NS}	0.1210**
WS	0.0845	0.1033	-	0.0256 ^{NS}	0.0217 ^{NS}	0.0138 ^{NS}	0.0137 ^{NS}	-0.0214 ^{NS}	-0.0041 ^{NS}	0.0918**
B	0.0319	0.0368	0.0930	-	-0.0014 ^{NS}	0.0012 ^{NS}	0.0162 ^{NS}	0.0045 ^{NS}	0.0115 ^{NS}	0.1244**
Ba	0.0350	0.0406	0.0971	0.0186	-	0.0030 ^{NS}	0.0148 ^{NS}	0.0073 ^{NS}	0.0140 ^{NS}	0.1180**
Bb	0.0519	0.0544	0.0882	0.0355	0.0440	-	0.0101 ^{NS}	-0.0063 ^{NS}	0.0037 ^{NS}	0.1115**
Bc	0.0841	0.0692	0.1083	0.0647	0.0656	0.0660	-	-0.0110 ^{NS}	0.0240 ^{NS}	0.1130**
Bd	0.1180	0.1232	0.1388	0.1091	0.1140	0.1057	0.1052	-	-0.0142 ^{NS}	0.0983*
Be	0.0920	0.0823	0.1270	0.0883	0.0916	0.0880	0.1263	0.1387	-	0.1192 ^{NS}
Hol	0.2416	0.2309	0.2305	0.2294	0.2301	0.2267	0.2365	0.3009	0.2860	-

p -values were obtained after 4,500 permutations; NS = Not significant, * $p < 0.05$, ** $p < 0.01$.

Indicative adjusted nominal level (5%) for multiple comparisons is 0.0011.

WT = White coat mixed with brown, BL = Black coat mixed with brown, WS = White spotted coat separated with brown, B = Hanwoo cattle with a cuticolor nose and pure brown coat, B (a to e): B (a to e): a-e represent different degree of nose pigmentation with "a" being the lightest and "e" the darkest, Hol = Holstein animals utilized as dairy cattle in Korea.

responsible for irregular spot shapes such as those seen in Holstein or Guernsey cattle while the S^H allele was expressed in breeds such as Hereford with white spots on the head. Research on the polymorphic characteristics of the sixth intron in *c-KIT* receptor gene (Jang et al., 2002) revealed four bases substitutions in animals of several different breeds, including Hanwoo, with white spots. These had different frequencies according to breed. It was reported that there is no indication of relationship between breeds. In other words, physical Hanwoo characteristics such as white hair, black hair, and white spots could be determined by alleles at a certain locus in different chromosomes, and even the same hair could differ in shade between groups of cattle.

Results of the NJ tree by D_A genetic distance showed the bootstrap values of each cluster (Figure 2). It was confirmed that both black nose pigmentation and different hair color characteristics of Hanwoo cattle formed a single small group with a normal group, which was not similar to other groups with different hair colors. The white spot group formed a group in a somewhat distant area, and the Holstein breed was confirmed to exist as an outside group comparatively distant from the Hanwoo group. An analysis using 17 microsatellites to make comparison between breeds confirmed that a group with a 74% bootstrap value was formed (Moazami-Goudarzi et al., 1997). However, construction of a flexibility dendrogram between breeds by randomly reselecting five out of 17 microsatellite markers confirmed that, a crowd with a fairly high 72% bootstrap value was formed between completely different groups even if the effect of the locus or reliability of the locus combination were very small (Moazami-Goudarzi et al., 1997). Moreover Moazami-Goudarzi et al. (1997) reported that polymorphic marker selection in or between groups is very important for selecting the appropriate number of microsatellite markers, getting the result accurately with sufficient reliability and repetitiveness. Gradually increasing the number of markers could increase the accuracy of this type of analysis. Although it is expected that this would lead to biased results if the locus was fixed

in a certain group (Hanwoo), the Hanwoo *INRA035* locus was included in our analysis of genetic distance. Thus, using information from the analysis of the 22 microsatellite loci rather than a bootstrap value increased dendrogram reproducibility. Results of this study showed that there was no difference in genetic distance or F-statistics. In our study, results of NJ tree analysis based on D_A genetic distance revealed that there was a group in which significant difference is not recognized despite the high bootstrap value in the F_{st} analysis and in the dendrogram that used the genetic distance of each individual animal. Thus, as the result of accurate analysis through the selection of markers by expected heterozygosity, F_{st} and random markers reported by Rosenberg et al. (2001), accurate analysis of the dendrogram is determined by using the marker with high polymorphism or F-statistics than using the number of markers.

Analysis of the Hanwoo group with black nose stages 3 to 5 showed that stage 5 (Be) animals had a closer genetic distance with the normal appearance group (B) than the stage 4 (Bd). In the appearance test on black nose, eye measurement was big error factor. The utmost reason of the low bootstrap value in dendrogram can be explain with the admixture between two groups (Felsenstein, 1982), and also caused by analysis of locus showing particularity for a certain group only (Moazami-Goudarzi et al., 1997; Martín-Burriel et al., 1999; Cañon et al., 2001). However, considering that our study involved the classification of a group of Hanwoo according to physical characteristics and PIC value where each locus had an average of 0.648, this resulted from a random drift between genetically closed groups and not by the number of markers or marker type (Lirón et al., 2006), or error arising the physical classification process.

To examine the degree of crowding and variance of actual individuals rather than between groups, a dendrogram was created by calculating all D_A genetic distance matrices of 399 animals used for our analysis. Similar to the results of the genetic distance matrix, the F_{st} test, and crowding analysis, the distribution was scattered in

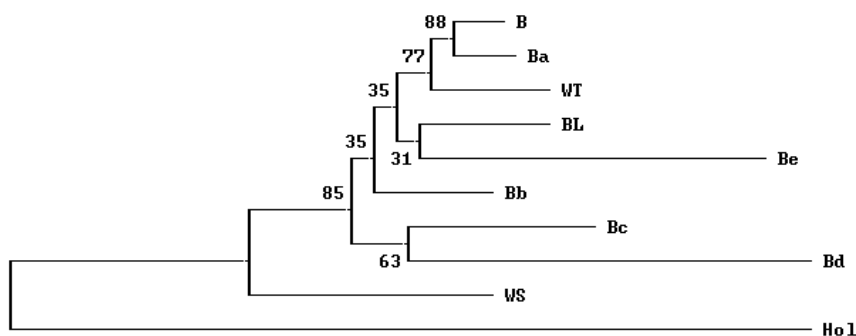

Figure 2. Neighbor-joining (NJ) tree showing the genetic relationships among the Hanwoo cattle using D_A genetic distances based on 22 microsatellite loci. The numbers on the nodes are percentage bootstrap values for 1,000 replications.

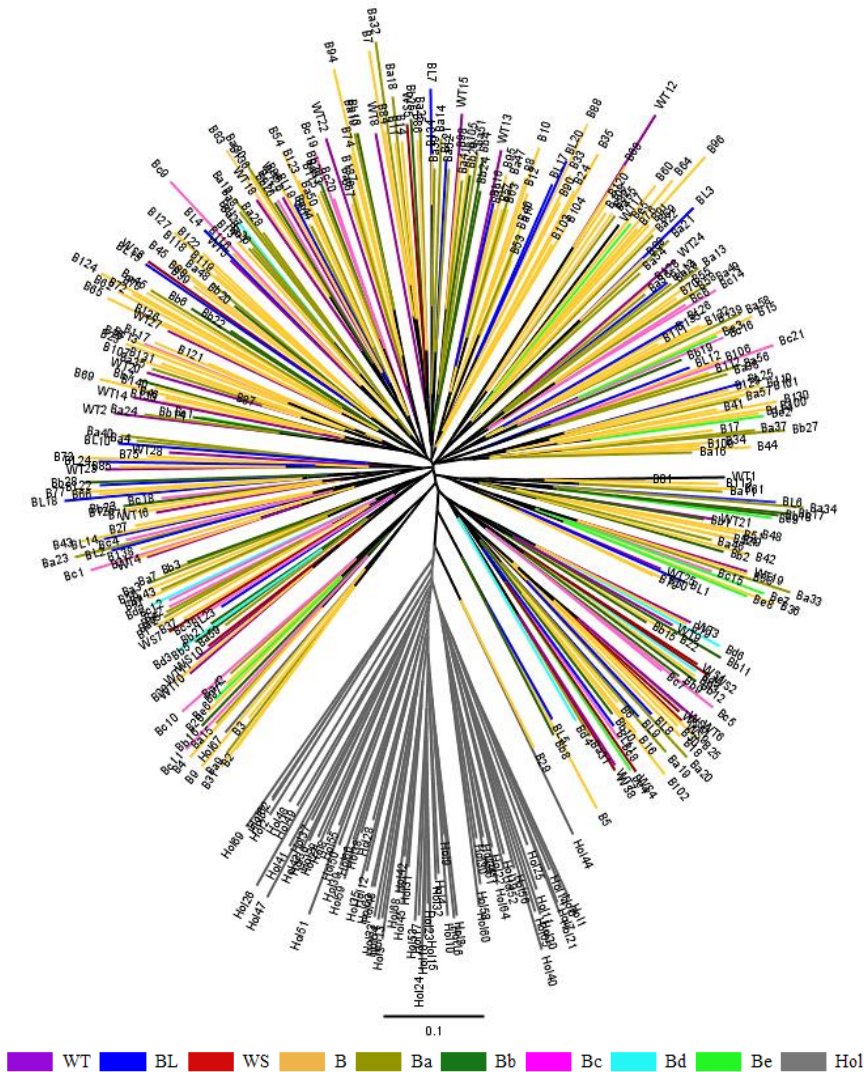

Figure 3. Neighbor-joining (NJ) dendrogram using D_A genetic distance within the individuals of 10 populations grouped according to phenotypic characteristics. WT = White coat mixed with brown, BL = Black coat mixed with brown, WS = White spotted coat separated with brown, B = Hanwoo cattle with a cuticolor nose and pure brown coat, B (a to e): a-e represent different degree of nose pigmentation with “a” being the lightest and “e” the darkest, Hol = Holstein animals utilized as dairy cattle in Korea.

normal cattle group and a certain crowd of Holstein alone was formed before creating a separate group based on different hair color or black nose pigmentation in Hanwoo (Figure 3). Thus, different hair color and black noses were a part of the general physical diversity among Hanwoo cattle.

In addition, 10 principal components were searched based on the results of a principal component analysis using allele frequencies obtained by analyzing the 22 microsatellites. Viscosity of the principal components including the second principal component is presented in Figure 4. Contribution to the variance of the principal components was over 90% including the fifth ingredient, and there was marked difference in the inherent value of the first and second principal components. However, a relatively high explanatory variance of 79.28% was observed, implicating the second principal component.

However, the results of principal component analysis, both the Hanwoo and Holstein groups existed in a positive direction of first ingredient, and the genetic difference between Holstein group and Hanwoo group was recognized. Moreover, it was confirmed that the Hanwoo group exists mostly on a similar x-axis.

For the second ingredient, each group contribution to the principal component was appeared in a normal appearance group, black nose stages 1 to 2, white hair and black hair group to the negative direction, and black nose stages 3 to 5 and white spot group appeared to the positive direction with Holstein breed. However, comparative variance of the second ingredient was much smaller than that of the first ingredient; it was found that variance did not exceed the inherent value 1, which was in contrast to variance of inherent value for the second ingredient. In the

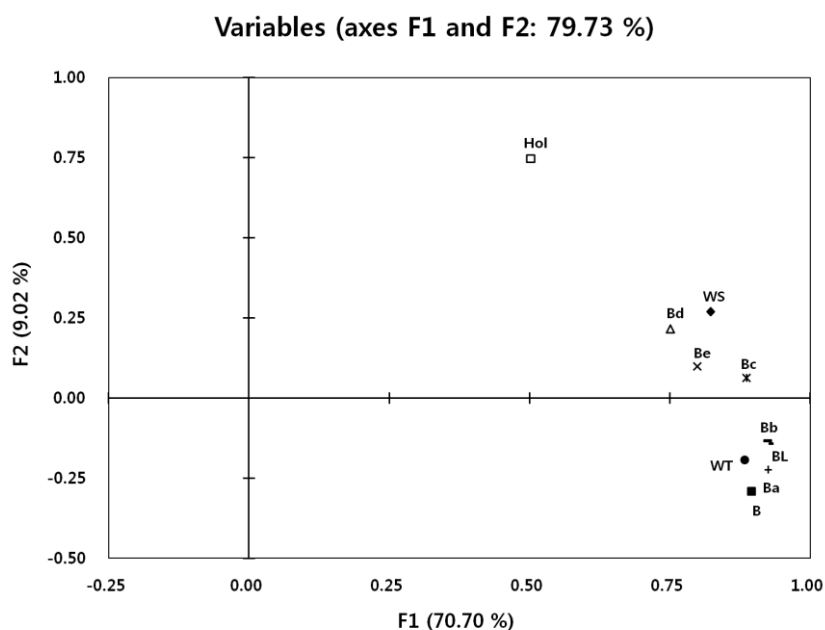

Figure 4. Principal component coordinates plot of each group based on correlations of allele frequencies for 22 microsatellite markers. WT = White coat mixed with brown, BL = Black coat mixed with brown, WS = White spotted coat separated with brown, B = Hanwoo cattle with a cuticolor nose and pure brown coat, B (a to e): a-e represent different degree of nose pigmentation with “a” being the lightest and “e” the darkest, Hol: = Holstein animals utilized as dairy cattle in Korea.

group with a very close relationship, differences were not explained by mutation but by genetic drift. This was in contrast to a certain direction in changes of genetic frequency by specific selection or mutation migration ratio. Since genetic drift was made by chance extraction of a gamete, changes in genetic frequency did not have a certain direction. This was likely to increase as the size of group decreases because it was in inverse proportion to the size of group (Takezaki and Nei, 1996; MacHugh et al., 1998; Laval et al., 2002). Additionally, evolution and origin of the breeds showed variations in the differentiation process. Evolution after isolation, selection, mutation, and migration results in differentiation, and then breeds can be formed by crossing. Thus, crowd formation and potential difference can be evaluated by studying the development of breeds in different environments (Cítek et al., 2006). Consequently, we identified genetic frequency changes associated with each black nose stage, consistent with previous observations (Lee et al., 2002). Our findings may be a result of genetic drift in Hanwoo cattle considering the differences in the numbers of individuals included in each black nose group.

CONCLUSION

This study showed that there was no significant difference for black nose stages 3 to 5. Results of the NJ tree analysis using genetic distance between individuals demonstrated that in different hair color-related group

except white spot or black nose group, spots were spread in normal appearance group. As a result of F_{st} analysis between groups, any significant differences between Hanwoo groups were recognized and there was other separate group formation for incoming or crossbreeding of introduced breeds. Moreover, white hair, black hair, and black noses in Hanwoo cattle are not phenotypical characteristics produced by crossbreeding with Holstein but rather actual Hanwoo characteristics that have been developed over a long period of time. The results of this study could be used for establishing criteria for Hanwoo physical traits. Applying strict standards for physical appearance to national bull selection is desirable for maintaining desirable physical characteristics. There is also a perception that moderate implementation of these criteria in farms could help reduce the economic losses of the Hanwoo cattle industry. Thus, further research should be conducted to analyze the genes associated with black nose pigmentation or different coat colors.

ACKNOWLEDGEMENTS

This work was supported by a grant from the Next-Generation BioGreen 21 Program (no. PJ0081912011), Rural Development Administration and Suncheon National University research fund (2009), Republic of Korea.

REFERENCES

Aasland, M., J. Klungland and S. Lien. 2000. Two polymorphisms

- in the bovine mast cell growth factor (*MGF*). *Anim. Genet.* 31:346.
- Boom, R., C. J. A. Sol, M. M. M. Salimans, C. L. Jansen, P. M. E. Wertheim-Van Dillen and J. Van der Noorda. 1990. Rapid and simple method for purification of nucleic acids. *J. Clin. Microbiol.* 28:495-503.
- Cañón, J., P. Alexandrino, I. Bessa, C. Carleos and Y. Carretero. 2001. Genetic diversity measures of local European beef cattle breeds for conservation purposes. *Genet. Sel. Evol.* 33:311-332.
- Cítek, J., L. Panicke, V. Rehout and H. Procházková. 2006. Study of genetic distances between cattle breeds of Central Europe. *Czech J. Anim. Sci.* 51:429-436.
- Cockerham, C. C. and B. S. Weir. 1993. Estimation of gen flow from F-statistics. *Evolution* 47:855-863.
- El Mousadik, A. and R. J. Petit. 1996. High level of genetic differentiation for allelic richness among population of the tree (*Argania spinosa*(L.) Skeels) endemic to Morocco. *Theor. Appl. Genet.* 92:832-839.
- Felsenstein, J. 1982. How can we infer geography and history from gene frequencies? *J. Theor. Biol.* 96:9-20.
- Felsenstein, J. 2007. PHYLIP. Version. 3.67. Department of Genetics, University of Washington, Seattle, USA.
- Goudet, J. 2001. FSTAT, a program to estimate and test gene diversities and fixation indices (version 2.9.3). Available from <http://www.unil.ch/izea/software/fstat.html>
- Ibeagha-Awemu, E. M., O. C. Jann, C. Weimann and G. Erhardt. 2004. Genetic diversity, introgression and relationships among West/Central Africa cattle breed. *Genet. Sel. Evol.* 36:673-690.
- Jang, Y. S., T. H. Kim, D. H. Yoon, E. W. Park, H. W. Lee, H. K. Lee and I. C. Cheong. 2002. A study on DNA polymorphism of the bovine c-KIT receptor gen. *J. Anim. Sci. Technol. (Kor.)* 44:653-660.
- Jordana, J., P. Alexandrino, A. Beija-Periera, I. Bessa, J. Canon and Y. Carretero. 2003. Genetic structure of eighteen local south european beef cattle breeds on microsatellite data. *Anim. Genet.* 33:201-204.
- Kim, K. S., J. H. Eum and C. B. Choi. 2001. Genetic diversity of Korean cattle using microsatellite analysis. *J. Anim. Sci. Technol. (Kor.)* 43:599-608.
- Korea Animal Improvement Association. 1997. Standard of judging Hanwoo (public notice 97-7).
- Laval, G., M. SanCristobal and C. Chevalet. 2002. Measuring genetic distances between breeds: use of some distances in various shortterm evolution models. *Genet. Sel. Evol.* 34:481-507.
- Lee, S. S., B. S. Yang, Y. H. Yang, S. Y. Kang, S. B. Ko, J. K. Jung, W. Y. Oh and S. J. Oh. 2001. Analysis of melanocortin receptor 1 (MC1R) genotype in Korean brindle cattle and Korean cattle with. *J. Anim. Sci. Technol. (Kor.)* 44:23-30.
- Leipold, H. W., K. Huston and K. N. Gelatt. Complete albinism in a Guernsey calf. *J. Hered.* 59:218-220.
- Lirón, J. P., P. Peral-García and G. Giovambattista. 2006. Genetic characterization of Argentine and Bolivian Creole cattle breeds assessed through microsatellites. *J. Hered.* 97:331-339.
- Loftus, R. T., O. Ertugrul, A. H. Harba, M. A. A. El-Barodys, D. E. MacHugh, S. D. E. Park and D. G. Bradley. 1999. A microsatellite survey of cattle from a centre of origin: the Near East. *Mol. Ecol.* 8:2015-2022.
- MacHugh, D. E., R. T. Loftus, P. Cunningham and D. G. Bradley. 1998. Genetic structure of seven European cattle breeds assessed using 20 microsatellite markers. *Anim. Genet.* 29:333-340.
- Martín-Burriel, I., E. García-Muro and P. Zaragoza. 1999. Genetic diversity analysis of six Spanish native cattle breeds using microsatellites. *Anim. Genet.* 30:177-182.
- Martín-Burriel, I., C. Rodellar, J. A. Lenstra, A. Sanz, C. Cons, R. Osta, M. Reta, S. D. Argüello, A. Sanz and P. Zaragoza. 2007. Genetic diversity and relationships of endangered Spanish cattle breeds. *J. Hered.* 98:697-700.
- Mateus, J. C., M. C. T. Penedo, V. C. Alves, M. Ramos and T. Rangel-Figueiredo. 2004. Genetic diversity and differentiation in Portuguese cattle breeds using microsatellites. *Anim. Genet.* 35:106-113.
- Minch, E. 1998. MICROSAT. Version 1.5b. University of Stanford, Stanford, CA, USA.
- Moazami-Goudarzi, K., D. Laloe, J. P. Furet and F. Grosclaude. 1997. Analysis of genetic relationships between 10 cattle breeds with 17 microsatellites. *Anim. Genet.* 28:338-345.
- Mukesh, M., M. Sodhi, S. Bhatia and B. P. Mishra. 2004. Genetic diversity of Indian native cattle breeds as analysed with 20 microsatellite loci. *J. Anim. Breed. Genet.* 121:416-424.
- Nei, M. 1983. Accuracy of estimated phylogenetics trees from molecular data. *J. Mol. Evol.* 19:153-170.
- Nei, M. 1987. Molecular evolutionary genetics. Columbia Univ. New York, USA.
- Olsen, T. 1981. The genetic basis for piebald patterns in cattle. *J. Hered.* 72:113-116.
- Olson, T. A. 1999. Genetics of color variation. In: *The Genetics of Cattle* (Ed. R. Fries and A. Ruvinsky). Wallingford, UK: CABI, p. 33.
- Ota, T. 1993. DISPAN. Pennsylvania State University, PA. USA.
- Pandey, A. K., R. Sharma, Y. Singh, B. B. Prakash and S. P. S. Ahlawat. 2006. Genetic diversity studies of Kherigarh cattle based on microsatellite markers. *J. Genet.* 85:117-122.
- Park, S. D. E. 2001. Trypanotolerance in west African cattle and the population genetic effects of selection. Ph. D. thesis. University of Dublin.
- Pawson, T. and A. Bernstin. 1990. Receptor tyrosine kinase: genetic evidence for their role in *Drosophila* and mouse development. *Trends Genet.* 6:350-356.
- Philippe, H. and M. Blanchette. 2007. Overview of the first phylogenomics conference. *BMC Evol Biol.* 7(supple 1):S1.
- Rao, C., D. Foemzler, S. K. Loftus, S. Liu, J. D. McPherson, K. A. Jungers, S. S. Apte, W. J. Pavan and D. R. Beier. 2003. A defect in a novel ADAMTS family member is the cause of the belted white-spotting mutation. *Development* 130:4665.
- Reinsch, N., H. Thomsen, N. Xu, M. Brink, C. Looft, E. Kalm, G. Brockmann, S. Grupe, C. Kühn, M. Schwenin, B. Leyhe, S. Heindleder, G. Erhardt, I. Medfugrac, I. Russ, M. Förster, R. Reents and G. Averdunk. 1999. A QTL for the degree of spotting in cattle shows synteny with the KIT locus on chromosome 6. *J. Hered.* 90:629-634.
- Roh, S. H. 2008. Studies on selection efficiency using ultrasound measurement trait in Hanwoo (Korean native cattle). Division of Animal Sciences, Gyeongsang Natl. univ. Ph. D. thesis.
- Rosenberg, N. A., T. Burke, K. Elo, M. W. Feldman, P. J. Freidlin, M. A. M. Groenen, J. Hillel, A. Mäki-Tanila, M. Tixier-Boichard, A. Vignal, K. Wimmers and S. Weigend. 2001.

- Empirical evaluation of genetic clustering methods using multilocus genotypes from 20 chicken breeds. *Genetics* 159:699-713.
- Saitou, N. and M. Nei. 1987. The neighbor-joining method: a new method for reconstructing phylogenetic trees. *Mol. Biol. Evol.* 4:406-425.
- Schmid, M., N. Saitbekova, C. Gaillard and G. Dolf. 1999. Genetic diversity in Swiss cattle breeds. *J. Anim. Breed. Genet.* 116:1-8.
- Schmutz, S. M., T. G. Berryere and C. C. Daniel. 2004. A form of albinism in cattle is caused by a tyrosinase frame shift mutation. *Mamm. Genome* 15:62-67.
- Seitz, J. J., S. M. Schmutz, T. D. Thue, F. C. Buchanan. 1999. A missense mutation in the bovine MGF gene is associated with the roan phenotype in Belgian Blue and Shorthorn cattle. *Mamm. Genome* 10:710-712.
- Seo, K., T. R. Mohanty, T. Choi and Inho Hwang. 2007. Biology of epidermal and hair pigmentation in cattle: a mini-review. *Veterinary Dermatol.* 18:392-400.
- Sodhi, M., M. Mukesh, B. Prakash, S. P. S. Ahlawat and R. C. Sobti. 2006. Microsatellite DNA typing for assessment of genetic variability in Tharparkar breed of Indian Zebu (*Bos indicus*) cattle, a major breed of Rajasthan. *J. Genet.* 85:165-170.
- Takezaki, N. and M. Nei. 1996. Genetic distances and reconstruction of phylogenetic trees from microsatellite DNA. *Genetics* 144:389-399.
- Vijh, R. K., M. S. Tantia, B. Mishara and S. T. Bharani Kumar. 2008. Genetic relationship and diversity analysis of Indian water buffalo (*Bubalus bubalis*). *J. Anim. Sci.* 86:1495-1502.
- Weir, B. S. 1990. Genetic data analysis. Sunderland, Massachusetts, Canada.
- Weir, B. S. 1996. Genetic data analysis II: methods for discrete population genetic data. Sunderland, Massachusetts, Canada.
- Yoon, D. H. 2002. Molecular genetic diversity and development of genetic markers in association with meat quality for Hanwoo (Korean cattle). Dept. of Animal Sciences, Korea Univ. Ph. D. thesis.
- Yoon, D. H., E. W. Park, S. H. Lee, H. K. Lee, S. J. Oh, I. C. Cheong and K. C. Hong. 2005. Assessment of genetic diversity and relationships between Korean cattle and other cattle breeds by microsatellite loci. *J. Anim. Sci. Technol. (Kor.)* 47:341-354.
- Zhang, G. X., Z. G. Wang, W. S. Chen, C. X. Wu, X. Han, H. Chang, L. S. Zan, R. L. Li, J. H. Wang, W. T. Song, G. F. Xu, H. J. Yang and Y. F. Luo. 2007. Genetic diversity and population structure of indigenous yellow cattle breeds of China using 30 microsatellite markers. *Anim. Genet.* 38:550-559.